



# MESSAGE FROM THE PRESIDENT



Throughout 2002-03, Palomar College celebrated its accomplishments and anticipated a positive future. Toward achieving our vision, "Learning for Success," and fulfilling the mission and objectives set forth in our Strategic Plan 2005, we embarked on a number of renovation projects, not only to several of our buildings, but also within our culture and District operations. I am delighted to present to you this annual report highlighting the successes of Palomar College students, faculty and staff in 2002-03.

Perhaps most significant in 2002-03 was the formation of Palomar College's new shared governance structure, intended to guide us to the successful achievement of our strategic plan. The major benefit of shared governance is the recognition that none of us, and no group of us, exists in isolation from the others. Faculty, staff, students, and administrators all have valuable insights and great wisdom about the work we do for our students. Working together to make decisions for Palomar College, we can make the best use of the resources available to us and provide an excellent education for our students.

Palomar College is one of the largest community colleges in San Diego County and California, serving about 30,000 students each year. We offer comprehensive academic, career training and educational programs. Our courses are taught by knowledgeable and caring faculty members. Our support staff is highly dedicated to the mission of educating our students and community. We suffered cuts to our budget in 2002-03, but not to our commitment. We had to reduce some services in 2002-03, but not the quality of services we offer. We will continue to make the most of every resource available to us, to ready our students to succeed in four-year colleges and universities and the world of work and to engage our community in lifelong learning.

Your continued support of Palomar College over the years, whether through gifts, your time, a recommendation to a student, or a spoken word is most appreciated. I hope you'll take a moment out of your busy schedule to read this annual report and share with us pride in the outstanding students, faculty and staff of Palomar College.

Warm Regards,

*Sherill Lamador*



# BOARD OF DIRECTORS



Darrell L. McMullen, M.B.A.  
*President*



Michele T. Nelson, Ph.D.  
*Secretary*



Ralph G. Jensen, B.A.  
*Vice President*



Mark R. Evilsizer, M.A.  
*Trustee*



Nancy C. Chadwick, M.S.W.  
*Trustee*



Leo Melena  
*Student Trustee*

**Our Mission:** Palomar College is an educational leader committed to quality learning. We provide our community the knowledge, information, skills, and aesthetic appreciation necessary to live responsibly, effectively, and creatively in an interdependent and changing world.

**Our Values:** Palomar College is a learning community dedicated to achieving student success and cultivating a love of learning. We strive to improve performance and outcomes based on evidence. To provide the highest quality learning and cultural experiences, we are guided by our core values of:

- achieving excellence in teaching, learning and service;
- fostering integrity as the foundation for all we do;
- providing access to our programs and services;
- ensuring equity and fair treatment in all policies, processes, and procedures;
- celebrating diversity in people, philosophies, cultures, beliefs, programs, and learning environments;
- supporting inclusiveness of individual and community viewpoints in collaborative decision-making processes;
- promoting mutual respect and trust through open communication and actions; and
- supporting innovation to enhance and enrich learning environments and services.



*“Strategic Plan 2005” established priorities for serving our community and set a carefully planned course to reach our vision, “Learning for Success.” The Strategic Planning Council is Palomar College’s recognized participatory governance body.*

# GUIDED BY OUR STRATEGIC PLAN

## 2002-2003 Strategic Planning Council Members

**Sherrill L. Amador, Ed.D.**

*Superintendent/President*

**Michael Arguello, Ph.D.**

*Coordinator - Academic Technology Resources*

*Professor - Economics, History & Political Science*

**Chris Barkley, M.A.**

*Associate Professor - English*

**Michelle Barton, M.S.**

*Director - Institutional Research & Planning*

**William Bedford, B.S.**

*Part-time Professor - Physics*

**Bruce Bishop, M.A.**

*Director - Student Affairs*

**Judy Cater, M.A.**

*Professor/Librarian - Library Media center*

**Chris Champine**

*Associated Student Government - Vice President*

**Kathy Davis, B.A.**

*Support Specialist - Information Services*

*Vice President - CCE/AFT*

**Mike Dimmick**

*Network Specialist - Information Services*

**Judith Dolan, M.A.E.**

*Professor - Business Education*

**Bonnie Ann Dowd, Ph.D.**

*Associate Professor/Chair - Business Education*

**Mary Ann Drinan, M.S.**

*Associate Professor/Chair*

*Economics, History & Political Science*

**Judith Eberhart, M.A.**

*Counselor*

**Brian Engleman**

*Academic Department Assistant*

*Regional Occupational Program*

**Kristeen Fukunaga, M.S.**

*Professor - Chemistry*

**Nancy Galli, M.A.**

*Professor/Chair - Family & Consumer Sciences*

**Katheryn Garlow, Ph.D.**

*Coordinator/Professor*

*Professional Development/ESL*

**Jo Anne Giese**

*Administrative Assistant - Administrative Services*

**Lynda Halttunen, M.A.**

*Interim Dean - Counseling & Matriculation*

**Diane Lutz, M.S.**

*Assistant Superintendent*

*Vice President Instruction*

**Joseph Madrigal, M.A.**

*Assistant Superintendent/Vice President*

*Student Services*

**Leo Melena, A.A.**

*Executive Vice President*

*Associated Student Government, 1st semester*

*President*

*Associated Student Government, 2nd semester*

**Mary Millet, M.A.**

*Part-time Professor - English*

**Jack Miyamoto, Ed.D.**

*Assistant Superintendent/Vice President*

*Human Resource Services*

**Wilma Owens, M.A.**

*Interim Dean - Career & Technical Education*

**Jerry Patton, M.B.A.**

*Assistant Superintendent/Vice President*

*Finance & Administrative Services*

**Steve Perry, B.A.**

*Assistant Professor*

*Computer Science & Information Systems*

**Mollie Smith, M.S.**

*Interim Director - Vocational Programs*

**Sean Weimer**

*President - Associated Student Body, 1st semester*





# STUDENT SUCCESS

*Facilitate student learning and goal attainment by providing comprehensive educational programs and services in diverse, accessible formats and locations.*

Goal/Objective	Completed	Continous Process	In Progress
Increase scholarship recipients and donors through improved processes and procedures			✓
Provide comprehensive and innovative class scheduling options to improve accessibility and timely program and degree completion			✓
Create and implement a system to improve student fee collection and related services	✓		
Improve articulation with the area high schools at the discipline level and within student services			✓
Develop and implement programs and services to increase persistence, completion and transfer			✓

Training. About 80 percent of these graduates are now working as peace officers in San Diego and Riverside Counties.

- The Fire Fighter Academy graduated 95 graduates, about 95 percent of whom are now working as firefighters in Southern California. The Fire Fighter In-service Training Program provided in-service to the 525 fire fighters working in North San Diego County fire departments.
- The Paramedic Program graduated 44 licensed paramedics who are all now working as paramedics in Southern California.
- The Palomar College football team ranked fourth in the nation, while our cheerleading team brought home a second-place trophy from the national championships. Our wrestling team earned a state championship, and our wide range of athletic teams for men and women won eight conference championships in 2002-03. Forty-one student-athletes transferred to four-year colleges with athletic scholarships.
- CalWORKs, a program to provide educational opportunities and job experiences to low-income adult parents, served 1,136 students, nearly twice the previous year's total. More than 200 students in this program graduated from Palomar College and transferred to a four-year college.

- The Palomar College Foundation increased its scholarship fund by more than \$200,000, bringing its scholarship total to \$1,556,000. The Performing Arts League contributed more than \$3,000 to support students.
- The Institutional Review Committee and the Faculty Senate approved a revised, expertise-based Institutional Review process to include student learning outcomes measurement.
- The U.S. Department of Education certified Palomar College as a Hispanic Serving Institution. The certification will provide access to significant grant funding to serve under-represented students. One such program is the GEAR UP partnership with local schools to encourage young people to aspire to attend college. More than half of the 3,264 students served by Gear Up in 2002-03 were Hispanic.

- The District joined a data-sharing consortium with several local high school districts to improve college readiness of high school graduates.
- Sixty students graduated with an Associate Degree in Nursing (ADN). Nursing students passed the National Council Licensure Examination (the final step to obtaining a nursing license) at a rate of 98.5 percent, as compared to an 83 percent statewide pass rate.
- Dental students passed the Registered Dental Assisting Exams at a rate of 81.3 percent, as compared to the statewide pass rate of 68.9 percent.
- The Police Academy graduated 70 students who are now certified by the California Commission on Peace Officer Standards and





- The Speech and Debate Team ranked 10th in the nation from among 85 schools that advanced to national-level competition. At the national level, the team received the Huffer-Goldman Interpreter's Theatre Award for outstanding theatre.
- At the San Diego County Fair, art students won 26 Best of Class and 13 Best of Show awards. Students in our Cabinet and Furniture Technology, Drafting, Design, Diesel and Automotive Technology programs also won numerous Best of Show and Best of Class awards. The student newspaper, Telescope, won two Best of Show awards.
- The student newspaper, Telescope, was one of only four in the state to receive the Pacesetter Award, the most prestigious award given by the Journalism Association of Community Colleges.
- Sarah Strause, Stephen Keller, and Tom Chambers competed against all San Diego weekly news writers and won first place for an education story or series from the San Diego Chapter of the Society of Professional Journalists. Several journalism students also won awards from the San Diego Press Club for feature and news stories, opinion pieces, and web site.
- Sally Serrin made the All-Academic California first team for California Community Colleges.



# STUDENT SUCCESS

- Associated Student Government President Leo Melena was chosen regional president for the Nevada/California Region of Phi Theta Kappa.
- Tiffany Brown was one of only 15 recipients of the Jack Kent Cook Foundation Scholarship, earning a full scholarship for her junior and senior years at the University of California, Santa Barbara.
- Scholar-athlete Chris Shirley was named to the California Commission on Athletics.



## Facts & Figures

Number of Associate Degrees awarded in 2002-03 .....	1,156
Number of Certificates of Achievement awarded in 2002-03 .....	416
Number of Certificates of Proficiency awarded in 2002-03 .....	148
Number of Students who transferred to California State University .....	873
Number of Students who transferred to University of California .....	190
Number of Students prepared to transfer to a four-year institution .....	1,939*
Grade point average for Palomar transfer students in their first year at California State University .....	3.09*
Grade point average for California community college transfers in their first year at California State University .....	2.94*

\* 2001-02 data







Fall 2002 Enrollment by Ethnicity

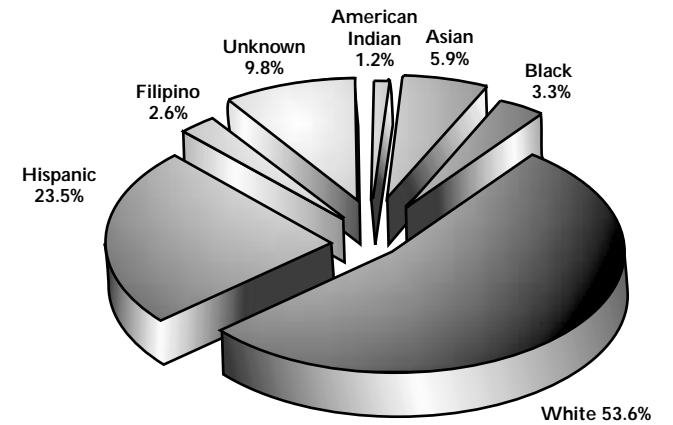

Enrollment Fall 1999-Fall 2002

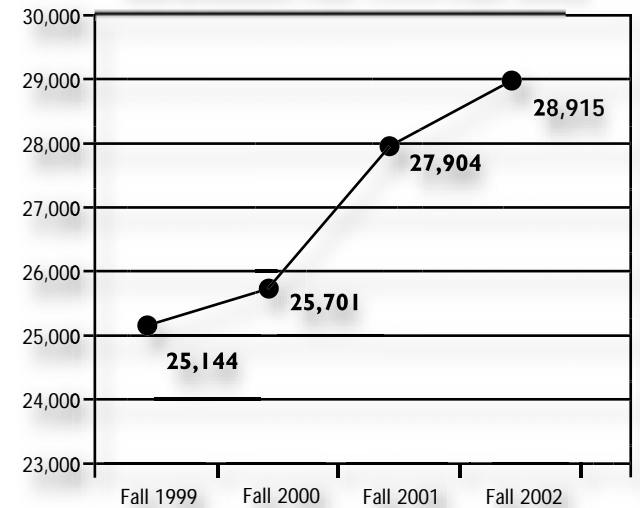



# TEACHING & LEARNING EXCELLENCE

*Provide exemplary teaching and learning environments and experiences to meet student needs through relevant curricula, innovation, partnerships, technology, research, and evaluation.*

Goal/Objective	Completed	Continous Process	In Progress
Foster a learning culture that promotes institutional and student expectations, responsibilities and respect			✓
Implement a user friendly curriculum process	✓		

Palomar College earned a full six-year accreditation, the highest possible, from the Accrediting Commission for Community and Junior Colleges of the Western Association of Schools and Colleges. Accreditation review involves a rigorous self-study process as well as a comprehensive four-day visitation and evaluation by a team of 12 community college educators from across the state. The accreditation team made several commendations to Palomar College, including:

- Dedication and commitment to providing quality learning environment and student support services.
- Well-managed college, highly dedicated faculty and staff and an exceptionally well-satisfied student body.
- Consistent focus on the college vision by faculty, administration, classified staff and students.
- Academic Technology Group, Library Media Center, website and e-services for students and staff.

Distinguished Faculty Award for Excellence in Teaching

**Steven Bertram**  
*Trades and Industry*

**Joseph Limer**  
*Economics, History & Political Science*

Faculty Service Awards

**Mary Ann Drinan**  
*Economics, History & Political Science*

**David Forsyth**  
*Business Education*

Employee of the Year Awards

CCE/AFT

**Jeff O'Bryant**  
*Information Services Technician*

Confidential and Supervisory Team

**Ralph Baker**  
*Admissions and Records*

Administrative Association

**Michelle Barton**  
*Institutional Research and Planning*



**Our Mission:** Palomar College is an educational leader committed to quality learning. We provide our community the knowledge, information, skills, and aesthetic appreciation necessary to live responsibly, effectively, and creatively in an interdependent and changing world.



# FACULTY & STAFF CELEBRATIONS



President's Awards

Student Success

**Marilyn Lunde**

*Student Affairs*

**Wendy Nelson**

*Telescope*

Teaching and Learning Excellence

**Pat Hahn**, *Communications*

*Cabinet & Furniture Technology Faculty*

Organizational and  
Professional Development

**Terri Canela**, *Professional Development*

Facilities Improvement

All members of the Educational and Facilities  
Master Plan Task Force

Resource Management

**Jerry Patton**, *Administrative Services*

**Lori Waite**, *Accreditation Self-Study Team*

**Kelly Hudson-McIssac**, *Accreditation  
Self-Study Team*



# ORGANIZATIONAL & PROFESSIONAL DEVELOPMENT

*Improve internal operations through effective communication and inclusive governance structures; strengthen and maintain professional development programs.*

Goal/Objective	Completed	Continous Process	In Progress
Implement a more timely process for approval and filling of new and replacement positions	✓		
Establish and fund ongoing employee training programs that assess needs, assure competencies and use appropriate delivery methods		✓	
Formalize a governance process that assures appropriate evaluation of and response to committee recommendations	✓		
Promote a culture of inclusiveness, participation, collaboration, and mutual respect that recognizes and celebrates the value of contributions		✓	
Delineate and integrate the District's organizational and governance structures	✓		

The Strategic Planning Council approved a new shared governance structure, established four planning councils, and revised committee structures to promote a culture of inclusiveness, participation, collaboration and mutual respect.

## Instructional Planning Council

Diane Lutz – Chair  
 Norma Bean  
 Pamela Brown  
 Terri Canela  
 Carolyn Funes  
 Katheryn Garlow  
 Rick Gommel  
 Lee Kerckhove  
 Nimoli Khurana  
 Carla Medina – ASG  
 Roger Morrisette  
 Sue Norton  
 Wilma Owens  
 Steve Perry  
 Mike Rourke  
 Teri Safranek  
 Susan Snow  
 Joe Stanford  
 Mark Vernoy

## Student Service Planning Council

Joe Madrigal – Chair  
 Rebecca Barr  
 Bruce Bishop  
 Judy Crowe  
 Sue Doran  
 José Fernandez  
 Marsha Gable  
 Lynda Halttunen  
 Herman Lee  
 Glenna Mitchell  
 Anne-Marie Mobilia  
 Benjamin E. Moss  
 Freddy Ramirez  
 Lorie Sousa  
 Eddie J. Tubbs  
 Lori E. Waite  
 John F. Woods

## Administrative Services Planning Council

Jerry Patton – Chair  
 Bruce Bishop  
 Judy Dolan  
 Mike Ellis  
 Espy Flores  
 Jo Anne Giese  
 Jerry Houser  
 Ken Jay  
 Becky McCluskey  
 Leo Melena  
 Jim Stoney  
 Don Sullins  
 Chris Wick

## Human Resources Planning Council

Jack Miyamoto - Chair  
 Donna Baughn  
 Nancy Horio  
 Patrick O'Brien  
 Jennifer Paris  
 Carmen Eckman  
 Helen Johnson  
 Rick Gommel  
 Erin Messersmith  
 Terri Canela

# OUR EMPLOYEES

Fall 2002 Ethnicity of Employees

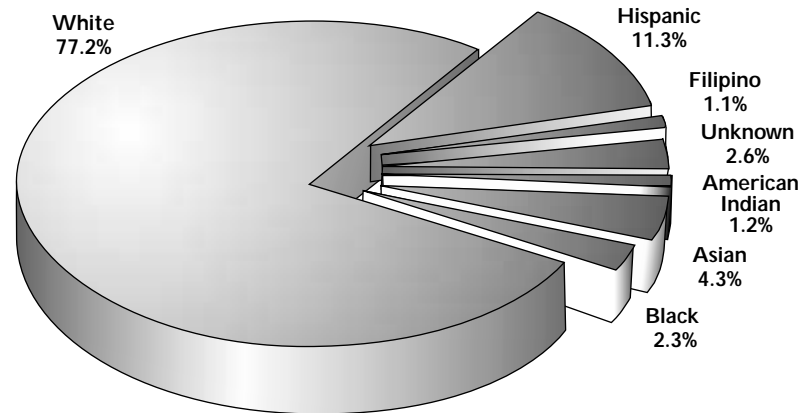

Fall 2002 Employees by Type

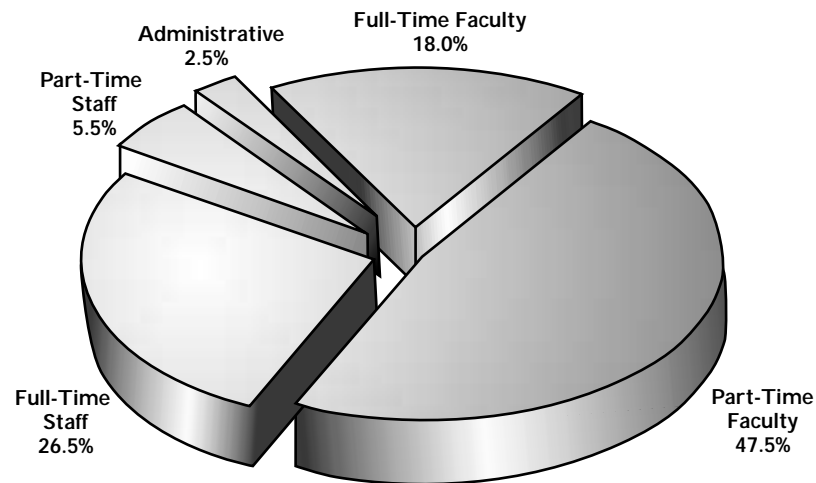



# RESOURCE MANAGEMENT

*Utilize existing human, physical, technological and fiscal resources efficiently and effectively and increase external funding.*

Goal/Objective	Completed	Continous Process	In Progress
Explore options for flexible multi-year departmental budget			Under Review
Continue efforts to make budget reports user friendly			✓
Develop and implement institutional strategies to lobby for community college interests and funding	✓		
Develop and implement a long-range budget plan for computer hardware and software upgrades and/or replacement			✓

- The newly-formed Government Affairs Committee led advocacy efforts including a regional news conference, student rallies, letter-writing campaigns, opinion editorials and a community advocacy task force. Direct results of these efforts were a reduction in mid-year cuts to Palomar College by \$1.3 million and a reduction in proposed cuts to Palomar's 2003-04 budget by \$3.1 million.

## Economic Impact on the Local Community:

According to the San Diego State University Office of Research and Service for Post-Secondary Education, Palomar College continues to generate a significant economic impact on the local community equal to that of a sizeable business enterprise. The College functions as an employer, consumer of goods and services, investor, landowner and builder.

Palomar College contributed \$135 million to local area wealth in 2001-02 through purchasing activity, payroll, Foundation expenditures, student financial aid, and indirectly through local businesses that provide goods and services to the College.

The College's economic activity also contributed to 7,618 jobs in the local community for 2001-02. Palomar employed 1,288 full-time-equivalent employees in 2001-02. Based on a conservative job-creation formula, SDSU researchers suggest that Palomar College also accounted for an additional 6,330 jobs in the local community – belonging to men and women who supply goods and services to the College.

Palomar contributed \$8.2 million to the local financial credit base in 2001-02 through employees' savings and checking deposits in local financial institutions which then loan to area residents and businesses.



Palomar Community College District  
Fiscal Year 2002-2003  
General Fund Revenues

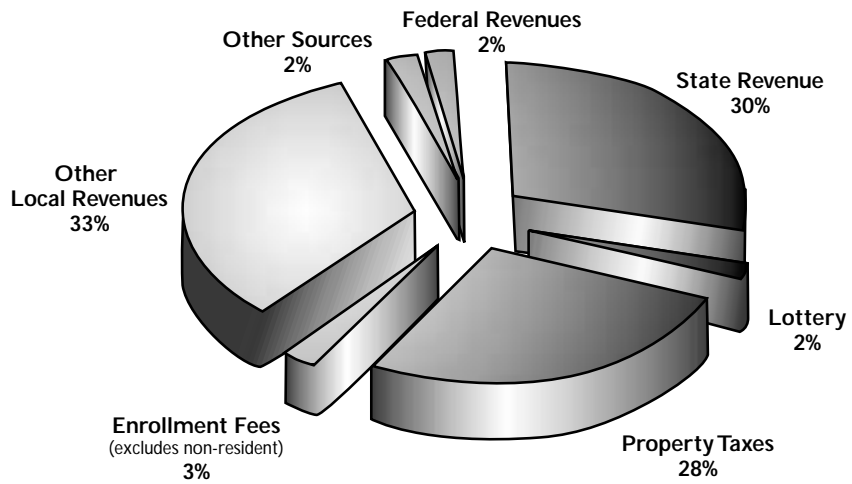

Palomar Community College District  
Fiscal Year 2002-2003  
General Fund Expenditures

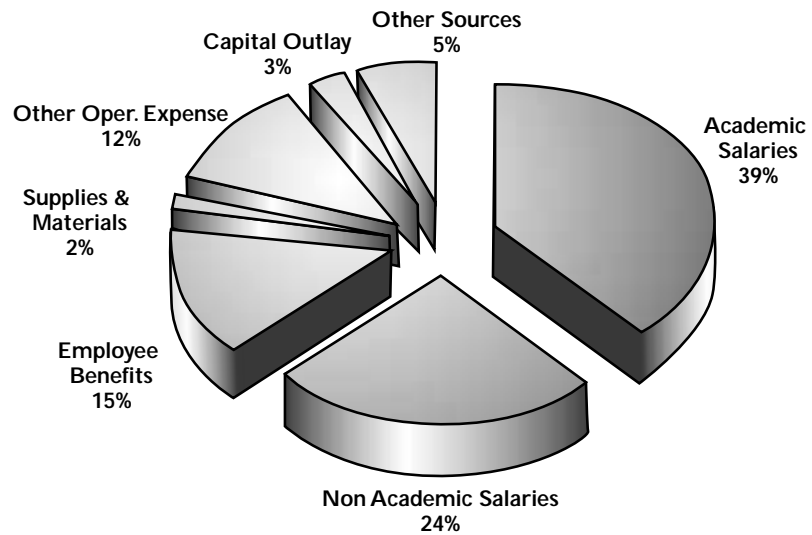

# FACILITIES IMPROVEMENT

*Enhance the aesthetic appearance, functionality, cleanliness, accessibility and safety of current facilities, while effectively planning for future needs based on educational programs and services.*

Goal/Objective	Completed	Continous Process	In Progress
Develop and fund an ongoing district-wide maintenance plan for buildings and grounds that demonstrates the commitment to a clean, attractive learning environment			✓
Complete and begin implementation of the Educational and Facilities Master Plan	✓		
Develop and implement a flexible parking plan that accommodates the needs of students, faculty, staff, and the community			✓
Evaluate and improve facilities-related safety and security throughout the District			✓

- Master Plan 2022 will guide the District in developing educational programs and facilities to accommodate 17,500 new students. The plan, developed by a team of faculty, staff, administrators and students, supports high-quality education and focuses on expanding the San Marcos campus as well as existing sites, establishing at least one new center in either the north or south portion of the District, and establishing at least one new campus in either the north or south portion of the District.

- The Student Center opened in June 2003.

- Final plans were submitted to the state for a high technology laboratory and classroom building. Construction is scheduled to begin in spring 2004.





# Educational and Facilities Master Plan Task Force

Sherrill Amador

Michelle Barton

Norma Bean

Neil Bruington

David Chase

Mike Ellis

Judy Fish

Carolyn Funes

Nancy Galli

Pat Hahn

Eamon Kavanagh

Kelley Hudson MacIsaac

Lee Kerckhove

Doug Key

Diane Lutz

Joe Madrigal

Leo Melena

Jerry Patton

Jason Roach

Buddy Springer

Lise Telson

Tom Ventimiglia

Mark Vernoy

Anne Voth

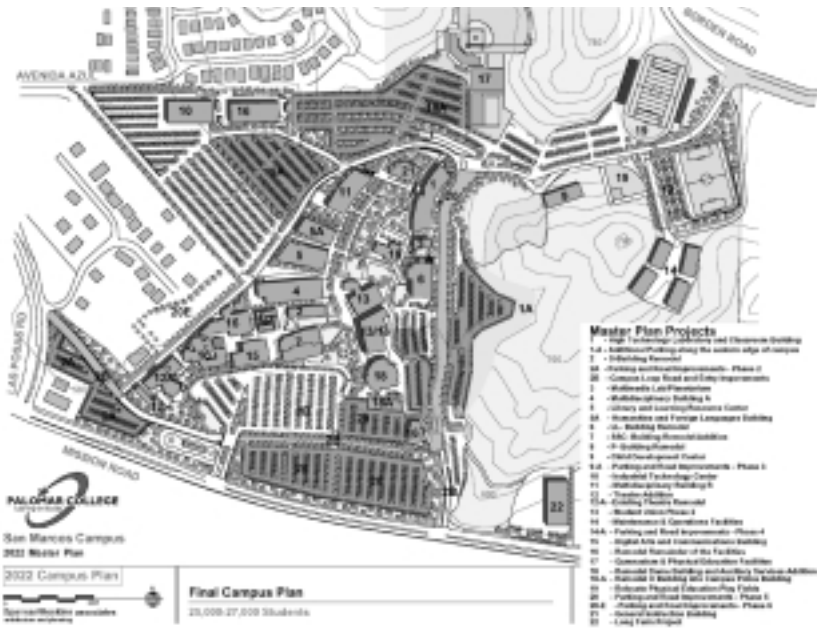

**Our Vision:** Palomar College is a learning community dedicated to achieving student success and cultivating a love of learning. We strive to improve performance and outcomes based on evidence. To provide the highest quality learning and cultural experiences, we are guided by our core values.



# PALOMAR COLLEGE FOUNDATION & PRESIDENT'S ASSOCIATES

During 2002-2003, the Palomar College Foundation total income was more than \$1.7 million. The Foundation holds one of the largest community college scholarship funds in California and manages and processes \$1.5 million in scholarships for Palomar College students each year. In 2002-03, the Foundation, along with the President's Associates and Lake San Marcos Friends of Palomar College, provided furniture and computers for the new Student Center, funded a study to assess the economic impact of Palomar College on the North San Diego County area, and sponsored several events designed to reach out to local high school students.

The Palomar College Foundation raises a significant portion of its funds through top-notch events such as the Lake San Marcos Friends of Palomar College Golf Tournament, the Palomar Goes! black-tie gala and the annual Wine & Dine event.

## Palomar College President's Associates Executive Committee

Bob Hahn, Chair  
Chris Carrick  
Ron Martin  
Don Bale  
Phil Dalsin  
Jim McAuley  
Doug Barker  
Mike Davis  
Marc McGuire  
Keith Beier  
Virginia Dower  
Mark Miller  
Mary Borevitz  
John Forst  
Debbie Thompson  
Richard Borevitz  
Dick High  
Raymond Bosch  
Scott Layton

## Palomar College Foundation Board of Directors

Sherrill L. Amador, Ed.D.  
Patti Anderson  
Kathleen Barber  
Jan E. Bourgeois  
Thomas B. Brown  
Christine Carrick  
Judy Cattell  
Luene Corwin, Ph.D.  
John W. Crawford, Esq.  
Sandy Hahn  
Granger Haugh  
George L. Liggins, M.P.H., Ph.D.  
Dennis C. Lindeman, MBA.  
Donna Luna de la Fuente  
Betsy Martin  
Richard McBride  
Paul M. Polito, CPA  
Bill Pultz, Esq.  
Charles Salter, Esq.  
Barbara Swearingen

## Lake San Marcos Friends of Palomar College

Wayman Alston  
Julia Anthony  
Ann Bulow  
Victor Freudenberger  
Joan Hausner  
Edna Hedge  
Elaine Jordan  
Kay King  
Elaine Landau  
Jim Lagerstrom  
Aggie LaHay  
Helen Minco  
Louis Pallares  
Elaine Papish  
Otto Roemmich  
Elva Turner

## Palomar College Foundation Board

Patti Anderson  
Thomas B. Brown  
Kathy Barber  
Jan Bourgeois  
Chris Carrick  
Judy Cattell  
Luene Corwin, Ph.D.  
John W. Crawford, Esq.  
Sandy Hahn  
Granger Haugh  
Jerry Horton  
George L. Liggins, M.P.H. Ph.D.  
Dennis C. Lindeman  
Donna Luna de la Fuente  
Betsy Martin  
Paul M. Polito, CPA  
Richard McBride  
Bill Pultz, Esq.  
Charles Salter, Esq.  
Barbara Swearingen





### Palomar College President's Associates

Patti Anderson  
 Carlos Arbelaez  
 Don Bale  
 Doug Barker, Esq.  
 Keith Beier  
 Richard and Mary Borevitz  
 Raymond Bosch  
 Bill and Lorraine Boyce  
 Thomas B. Brown  
 Bill Carman  
 Christine Carrick  
 Craig Conway  
 Phil Dalsin, Ph.D.  
 Mike Davis  
 Virginia Dower  
 Richard and Fia Dowsing  
 John Forst  
 Bob Glaser  
 Bob Hahn  
 Dick High  
 Ann Hunter-Welborn  
 Marlene Imirzian, AIA

Chris Johnson  
 Scott Layton  
 Matthew Lehrer  
 Richard Marino, Esq.  
 Ron Martin  
 Brad Mason  
 Jim McAuley  
 Marc McGuire  
 Josh Mellinger  
 Mark Miller  
 Angelo Mitchell  
 Corky Mizer  
 Mike Nicholson  
 Liz Nixon  
 Curt Noland  
 Larry O'Malley  
 Mike Onuma  
 Jeff Ritchie  
 John Sedlack  
 Lee Thibadeau  
 Debbie Thompson





1140 W. Mission Road  
San Marcos, California 92069  
(760) 744-1150  
[www.palomar.edu](http://www.palomar.edu)

**Our Mission:** Palomar College is an educational leader committed to quality learning. We provide our community the knowledge, information, skills, and aesthetic appreciation necessary to live responsibly, effectively, and creatively in an interdependent and changing world.

**Our Vision:** Palomar College is a learning community dedicated to achieving student success and cultivating a love of learning. We strive to improve performance and outcomes based on evidence. To provide the highest quality learning and cultural experiences, we are guided by our core values.