



## **NOTICE TO BIDDERS**

### **ADDENDUM #7 -**

### **Bid 103-22 Athletics Stadiums Re-bid Project**

#### **Palomar Community College District**

The following changes, additions, deletions, clarifications, or corrections shall become part of the Bid & Contract Documents for the above listed project. This Addendum #6 forms a part of the contract document and modifies the original bidding documents. Acknowledge receipt of Addendum #6 in the space provided on the bid form. Failure to do so may subject bidder to disqualification.

#### **NEW CLOSING DATE:**

The District has extended the due date for this Bid from Thursday, May 26, 2022 to **Tuesday, May 31, 2022, no later than 3:00PM**

#### **SUBSTITUTION REQUESTS**

The two (2) substitution requests were rejected

#### **REQUESTS FOR INFORMATION - QUESTIONS AND RESPONSES**

- (1) QUESTION: Addendum #6 Question 2 was drafted to clarify the temporary shoring scope per Addendum 3 keynote 28/C1.21. The Answer to Question 2 references a "Permanent Wall" that is not shown in the location of "Temporary Shoring" per keynote #28. There is no retaining wall shown along the fire lane per revised addendum #3-page C1.21. See attached describing the limits of keynote #21 for the wall (in red) and keynote #28 for the shoring (in yellow). It should further be noted that contract documents do not allow for a permanent wall with temporary shoring as the shoring would be roughly 10' into the fire lane necessitating the existing utilities to be rerouted. Please resolve the conflicts caused by the answers in addendum #6.

*RESPONSE: Response #2 – response revised: Confirmed. Shoring and OSHA compliant railing to remain in place after this contract (see attached).*

- (2) QUESTION: (Addendum 6) The answer to question #4a is in direct conflict with answer #4b which is a direct conflict with answer #4c. As this applies to the building foundations response (a. states EI < 50 but response (b. states not to exceed EI20 while response (c. states "Native materials are NOT suitable anywhere below the building pad or footing". Please confirm the correct answer is 4a. "fill material needs to have an EI < 50" is the correct response the question regarding soils at the building foundations. The addendum #6 has direct conflicts in it's answers that require another RFI to get clarity so all bidders can bid the same work requirements. These conflicts are significant and costly.

*RESPONSE: Response #4 – all responses are correct.  
4a – Generally for the project, fill materials must have expansion index < 50.  
4b – Where Select material is specified, Select materials need to have an expansion index < 20 per Geotechnical report.*

*4c – Native materials are not suitable below the building pad or footings.*

- (3) QUESTION: Addendum #6 issued substitutions requests for Metal Roofing Panels, and Dugout Furnishing. Please clarify if these substitutions are approved or rejected?

*RESPONSE: Substitutions previously submitted in Addendum #6, were rejected.*

**No Further Addendums will be issued  
END OF ADDENDUM #7**

Date Issued: May 24, 2022

*Richard J Taylor*

Richard J Taylor (May 24, 2022 17:40 PDT)

---

Richard Taylor, Interim Director Business Services  
Palomar Community College District





HMC Architects

501503000

3546 CONCOURS STREET  
ONTARIO, CA 91764  
T 909.989.9879 / www.hmcarchitects.com

ISSUE:

NO.	ISSUED	DATE
3	ADDENDUM 3	02.09.2022

Keynotes:

Notes:

Consultant:

**FUSCOE**  
ENGINEERING  
6390 Greenwich Dr., Suite 170  
San Diego, California 92122  
tel 858.554.4300 fax 858.597.0335 www.fuscoec.com



Facility:  
**PALOMAR COLLEGE**  
PALOMAR COMMUNITY COLLEGE DISTRICT  
1140 W. MISSION ROAD  
SAN MARCOS, CA 92069

Project:  
**PALOMAR COLLEGE - ATHLETICS PH1 -  
FOOTBALL & SOFTBALL FIELDS**

Sheet:  
**PRECISE GRADING PLAN**

DSA APPROVED SET

FILE NO.: 37-C1 A NO.: 04-120240  
Date: 01.18.2022 Client Project No.:

Sheet:

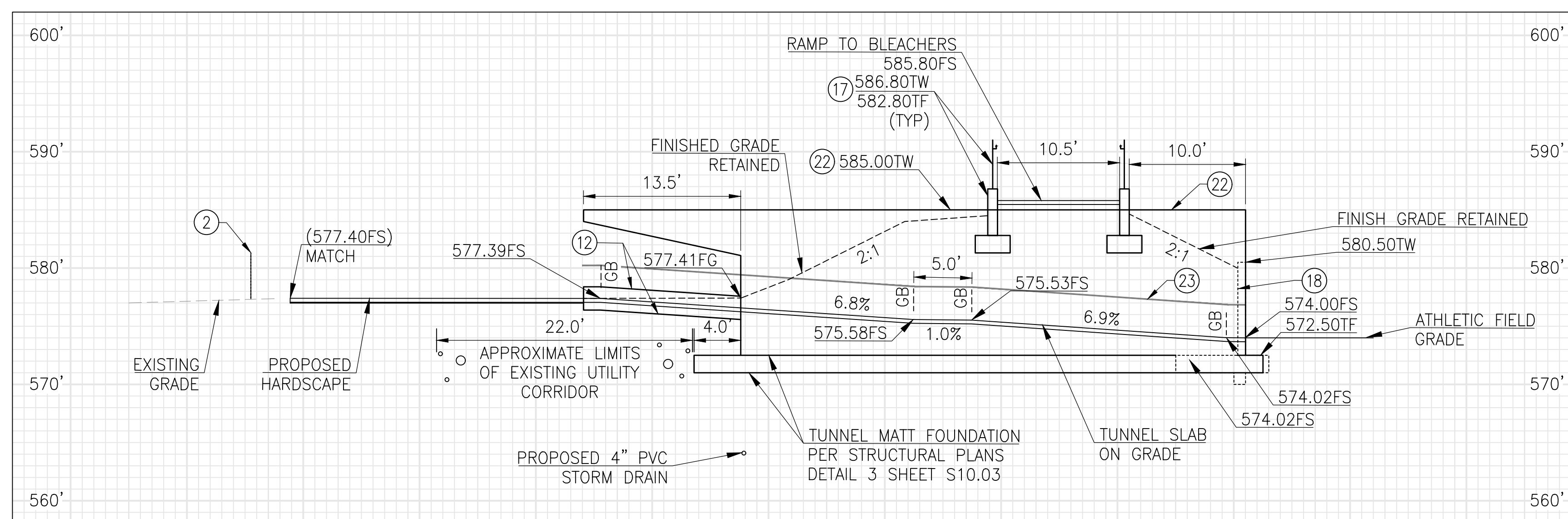

SITE SECTION DD  
NTS  
C1.21

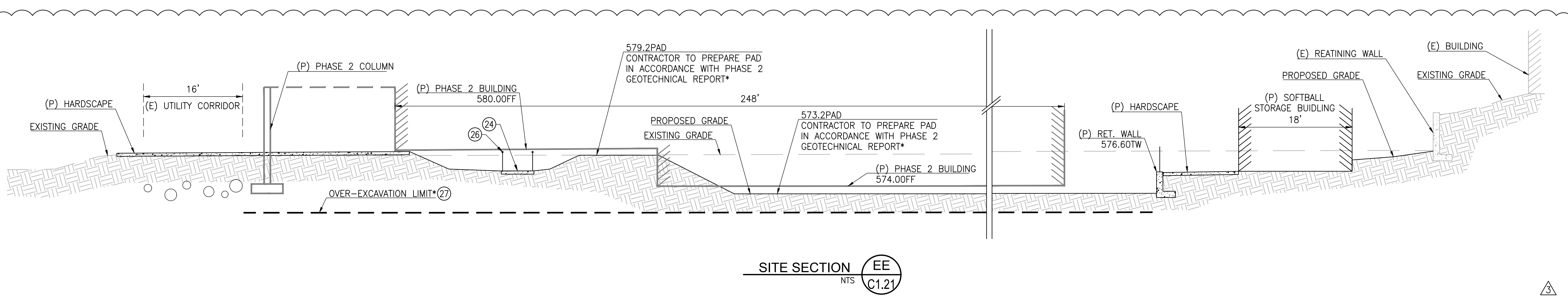

SITE SECTION EE  
NTS  
C1.21

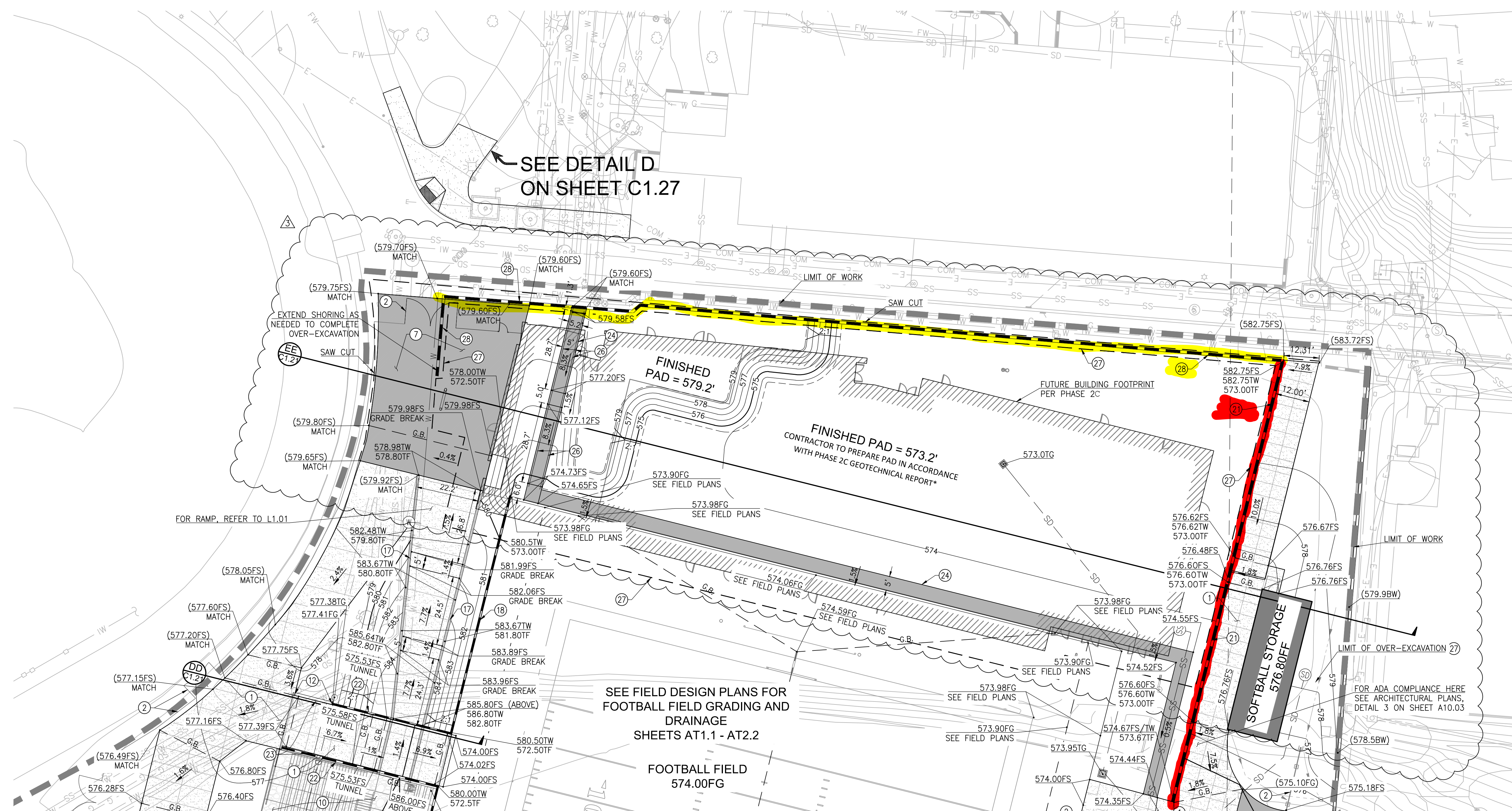

MATCHLINE SEE SHEET C1.22

MATCHLINE SEE SHEET C1.23

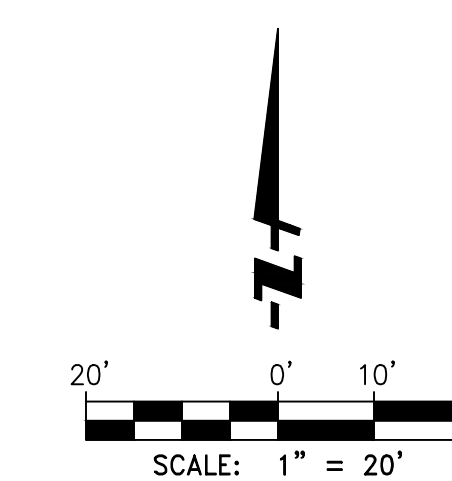

C1.21







# Addendum 7 - Bid 103-22 Athletics Stadium Re-bid Project.

Final Audit Report

2022-05-25

Created:	2022-05-25
By:	Debbi Claypool (dclaypool@palomar.edu)
Status:	Signed
Transaction ID:	CBJCHBCAABAATvO1BdpwLBwx68jSrGag2Uy0pRNtgI9V

## "Addendum 7 - Bid 103-22 Athletics Stadium Re-bid Project." History

-  Document created by Debbi Claypool (dclaypool@palomar.edu)  
2022-05-25 - 0:18:10 AM GMT- IP address: 205.153.156.222
-  Document emailed to Richard J Taylor (rtaylor1@palomar.edu) for signature  
2022-05-25 - 0:18:39 AM GMT
-  Email viewed by Richard J Taylor (rtaylor1@palomar.edu)  
2022-05-25 - 0:39:39 AM GMT- IP address: 104.47.57.126
-  Document e-signed by Richard J Taylor (rtaylor1@palomar.edu)  
Signature Date: 2022-05-25 - 0:40:03 AM GMT - Time Source: server- IP address: 73.189.143.230
-  Agreement completed.  
2022-05-25 - 0:40:03 AM GMT